

# SUPERTOUCH 49

SUPER 6 KEYBOARD REPLACEMENT  
INSTALLATION GUIDE

**U·D·O**



SECTION 1. **INSTALLING YOUR  
SUPERTOUCH 49**  
PAGES 04 – 19.

SECTION 2. **USING POLYPHONIC  
AFTERTOUCH**  
PAGES 20 – 21.

SECTION 3. **SUPPORT &  
TROUBLESHOOTING**  
PAGES 22 – 23.



# IMPORTANT SAFETY INSTRUCTIONS



## THE FOLLOWING SAFETY REQUIREMENTS MUST BE ADHERED TO FOR PREVENTION OF FIRE, ELECTRIC SHOCK OR INJURY:

1. Disconnect the instrument from the electrical supply and remove the power cord before attempting to install the retrofit kit.
2. Read all the instructions and check the contents of the kit before installation. If you are unsure of your understanding of the installation process, contact UDO.
3. Choose a suitable and stable location for performing the installation. Ensure that the chosen location provides adequate working space.
4. Do not perform the installation in the following types of locations:
  - On unstable or inadequately rated furniture
  - Locations exposed to moisture or dust
  - Locations exposed to rain
  - Locations of extremely high temperature or direct sunlight
  - Locations near to containers containing liquids
  - Locations where children are present
5. Do not drop the instrument or retrofit kit.
6. Do not use the instrument or connect to the electrical supply if damage is suspected to have occurred. In this case, contact UDO. The following may indicate signs of damage:
  - The musical instrument becoming wet (by rain, etc.)
  - The musical instrument becoming hot
  - Generation of smoke or an unusual smell
  - Repeated abnormal behaviour
  - Visible damage to the enclosure, for example large dents or holes in the enclosure
7. Do not allow foreign objects or liquids to enter the musical instrument, as this can cause permanent damage and may result in serious personal injury and possible ignition of the liquid if flammable. If damage from foreign objects or liquids entering the musical instrument is suspected, do not use the musical instrument or connect to the electrical supply, and contact UDO.

# KIT CONTENTS

---

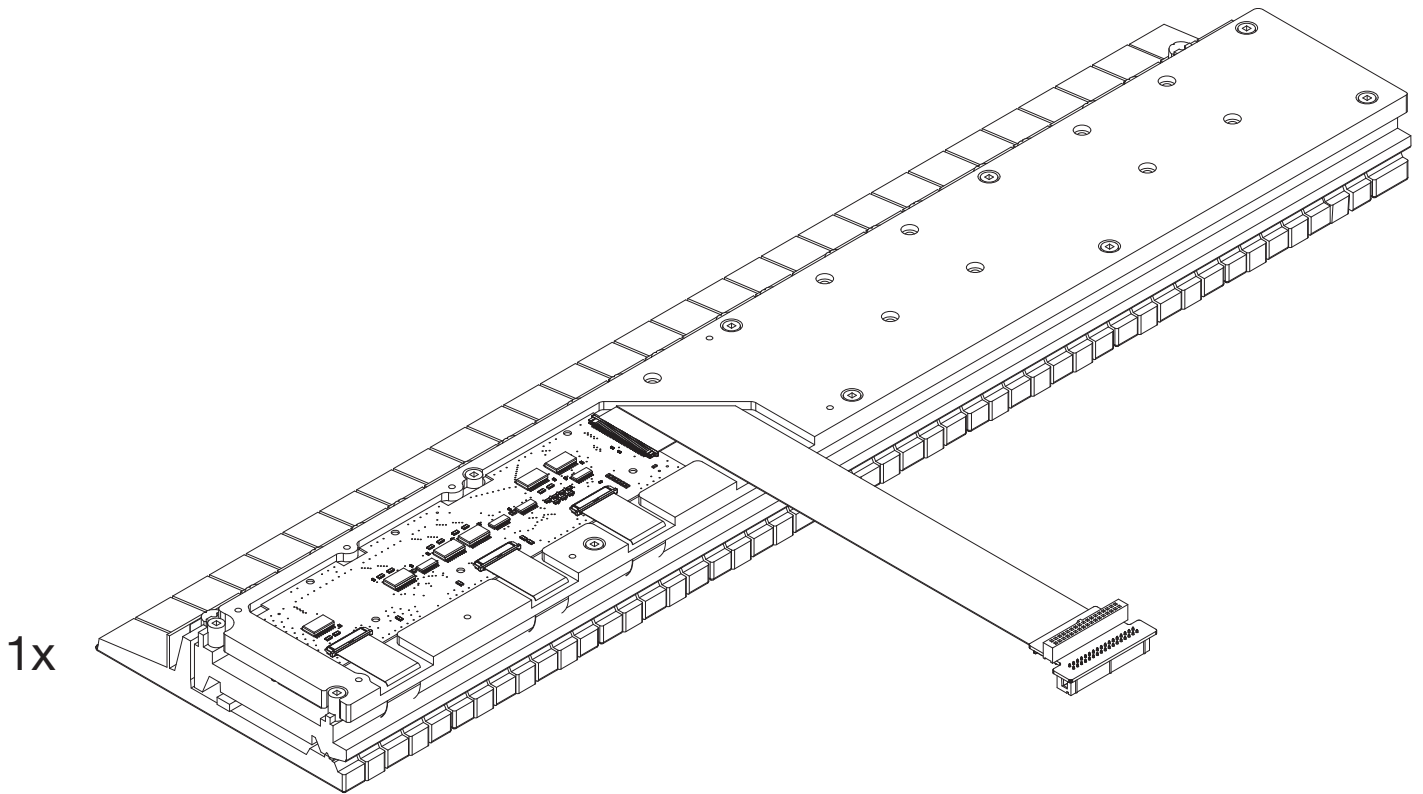

1x SuperTouch 49 keyboard and PCB adapter



10x

10mm Torx  
T20 screws

1x

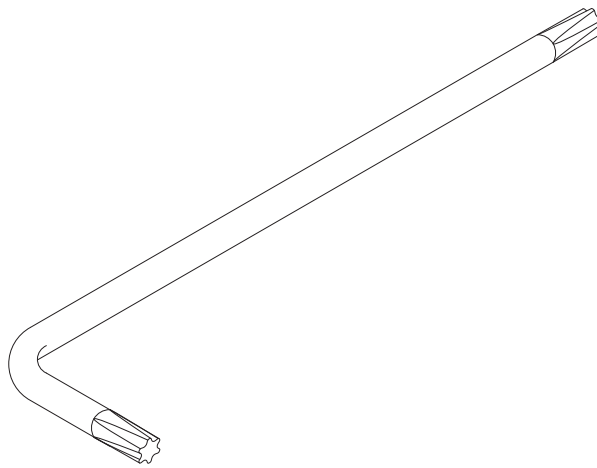

Torx T20 key

1x



SuperTouch 49  
decal sticker

# GENERAL NOTES ON INSTALLATION

---

1. Use the included 10mm Torx T20 screws for attaching the SuperTouch 49 keyboard. Do not reuse the original screws.



Depending on your serial number, the original screws may differ. While newer Super 6 models feature 14mm Torx T20 screws, older Super 6 models were fitted with Phillips head (“crosshead”) screws. To remove the latter, use a Phillips #1 screwdriver instead of the included Torx T20 key.

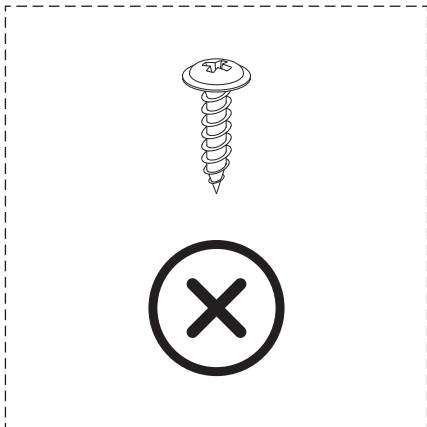

Original Phillips head screw.

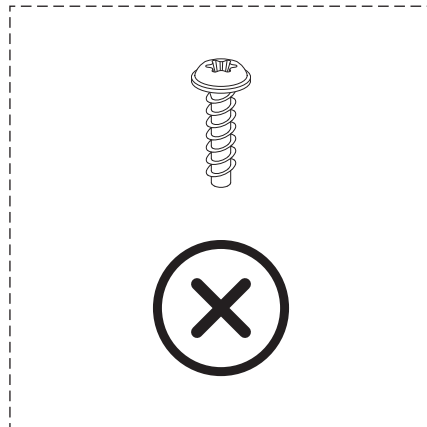

Original 14mm Torx T20 screw.

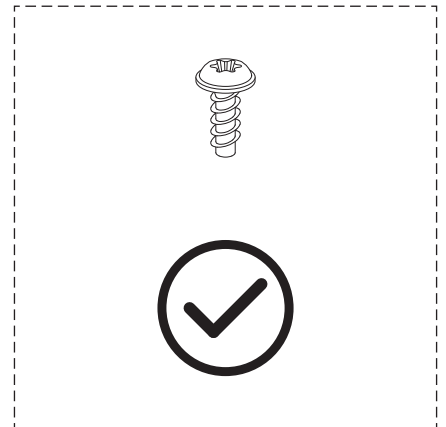

New 10mm Torx T20 screw.

2. Handle the SuperTouch 49 keyboard with care during installation, as the surface of the keyboard in particular can be easily scratched. We recommend using packaging foam as a soft base on which you can place the keyboard.

# INSTALLATION INSTRUCTIONS

1. Disconnect the mains cable from the Super 6.
2. Carefully lift the Super 6 onto its rear panel on a soft surface. Remove the two lid retaining screws and washers from the underside of the chassis and keep them in a safe place.

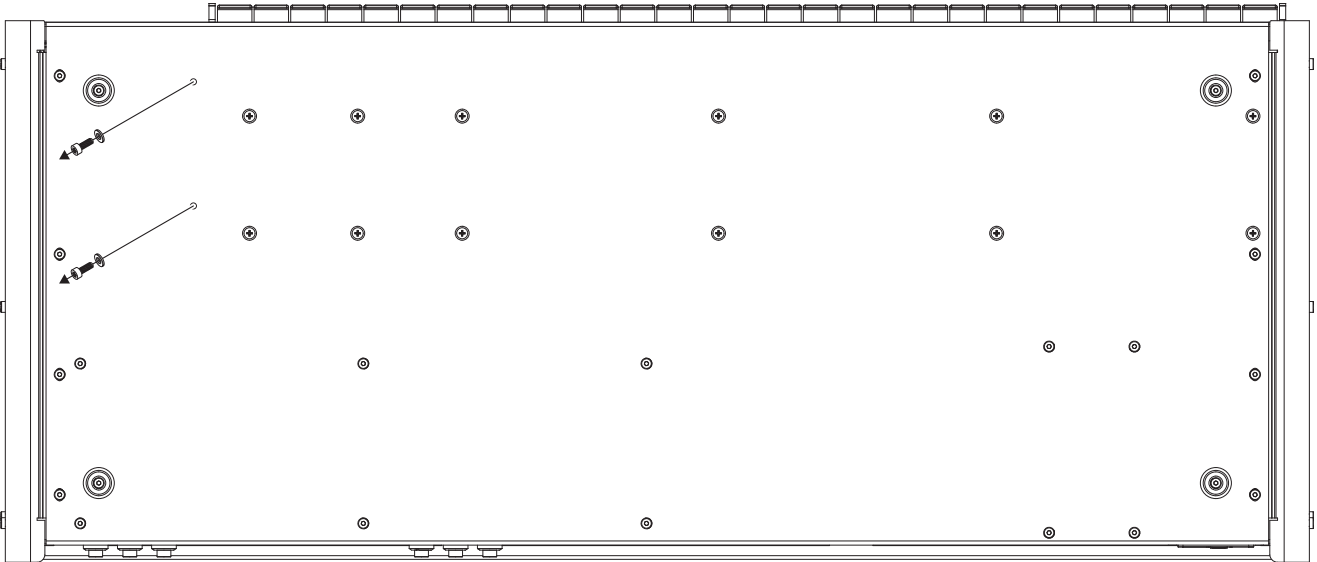

3. Remove the screws and washers from both side panels and keep them in a safe place.

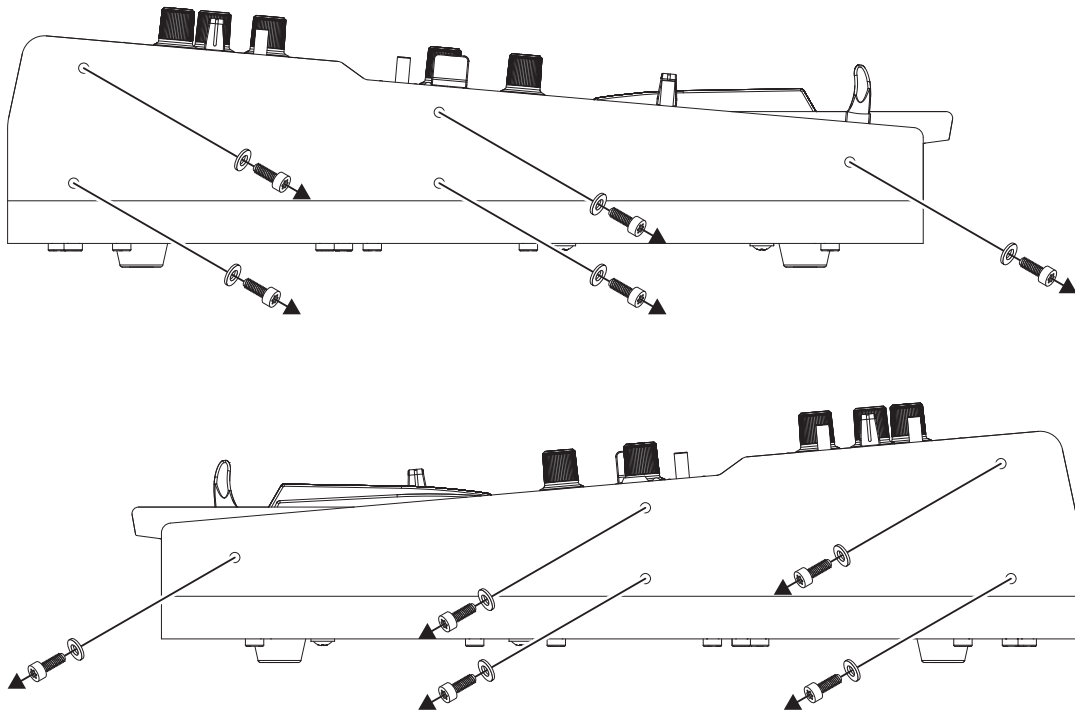

4. Lift the lid slightly and hold it firmly so that it does not fall off.

First remove the aftertouch strip of the keyboard by unplugging the blue connector near the bender assembly.

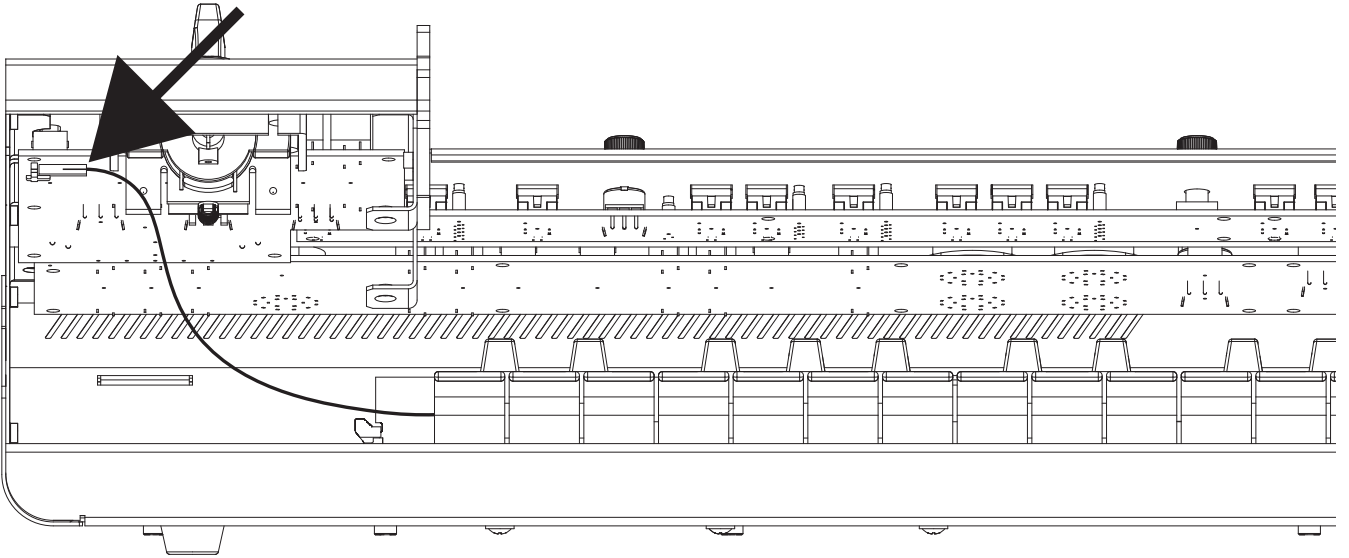

Then unplug the two keyboard cables from the main board.

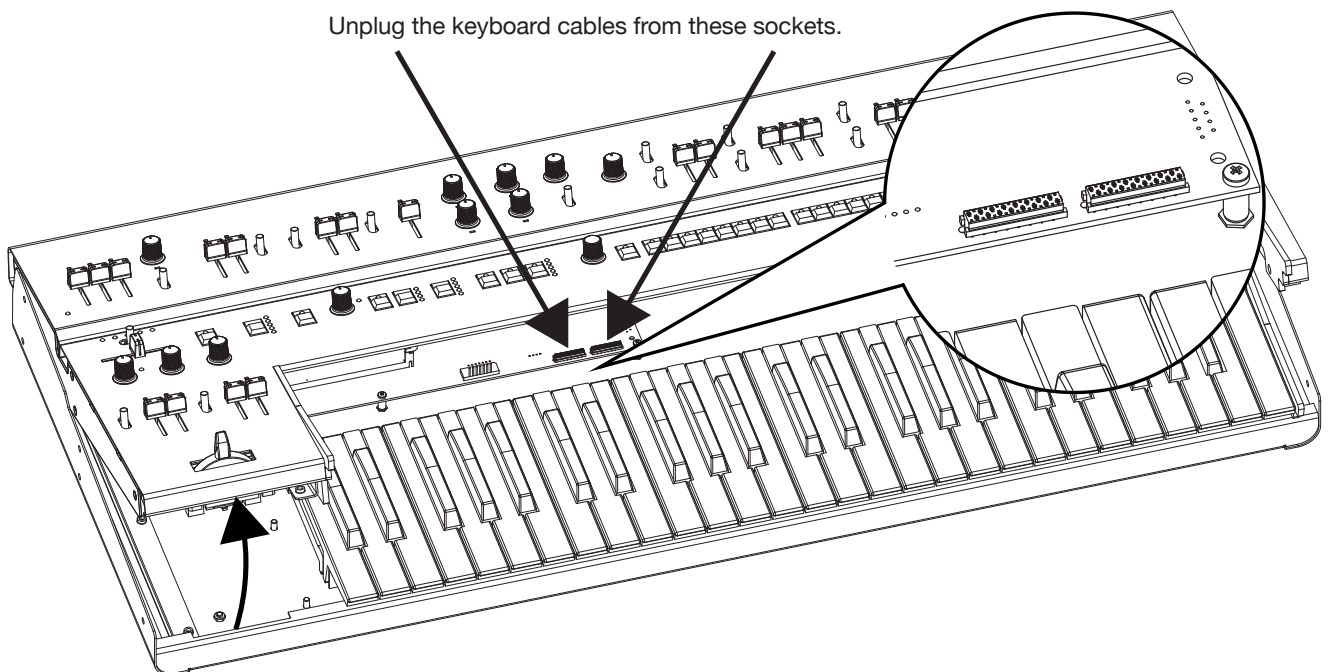

5. Close the lid and reattach the two lid retaining front screws and washers to both side panels, one on each side. This is to prevent the lid from falling open and being damaged when the Super 6 is lifted onto its rear panel in the next step.

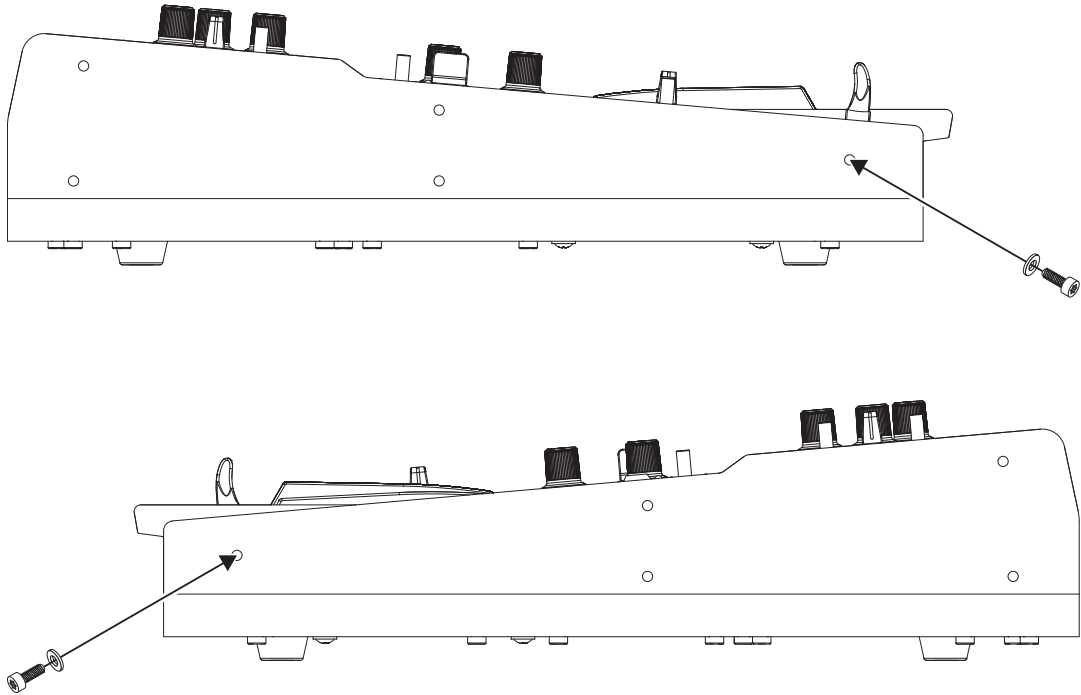

6. Carefully lift the Super 6 onto its rear panel on a soft surface. Remove the central eight screws that secure the keyboard.

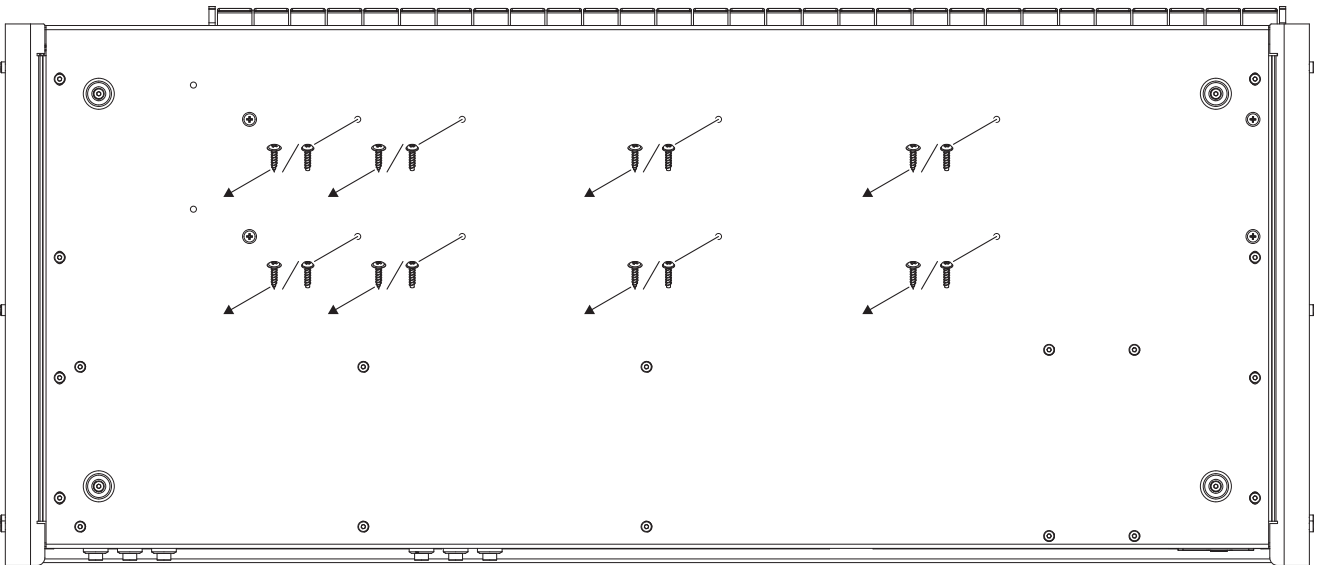

*Earlier Super 6 models were fitted with Phillips head (“crosshead”) screws. To remove these screws, use a Phillips #1 screwdriver instead of the included Torx T20 key.*

7. Remove the remaining four screws that retain the keyboard while holding the Super 6 flat. Slide the Super 6 so that it protrudes slightly above your workbench so that you can access the screws from below.

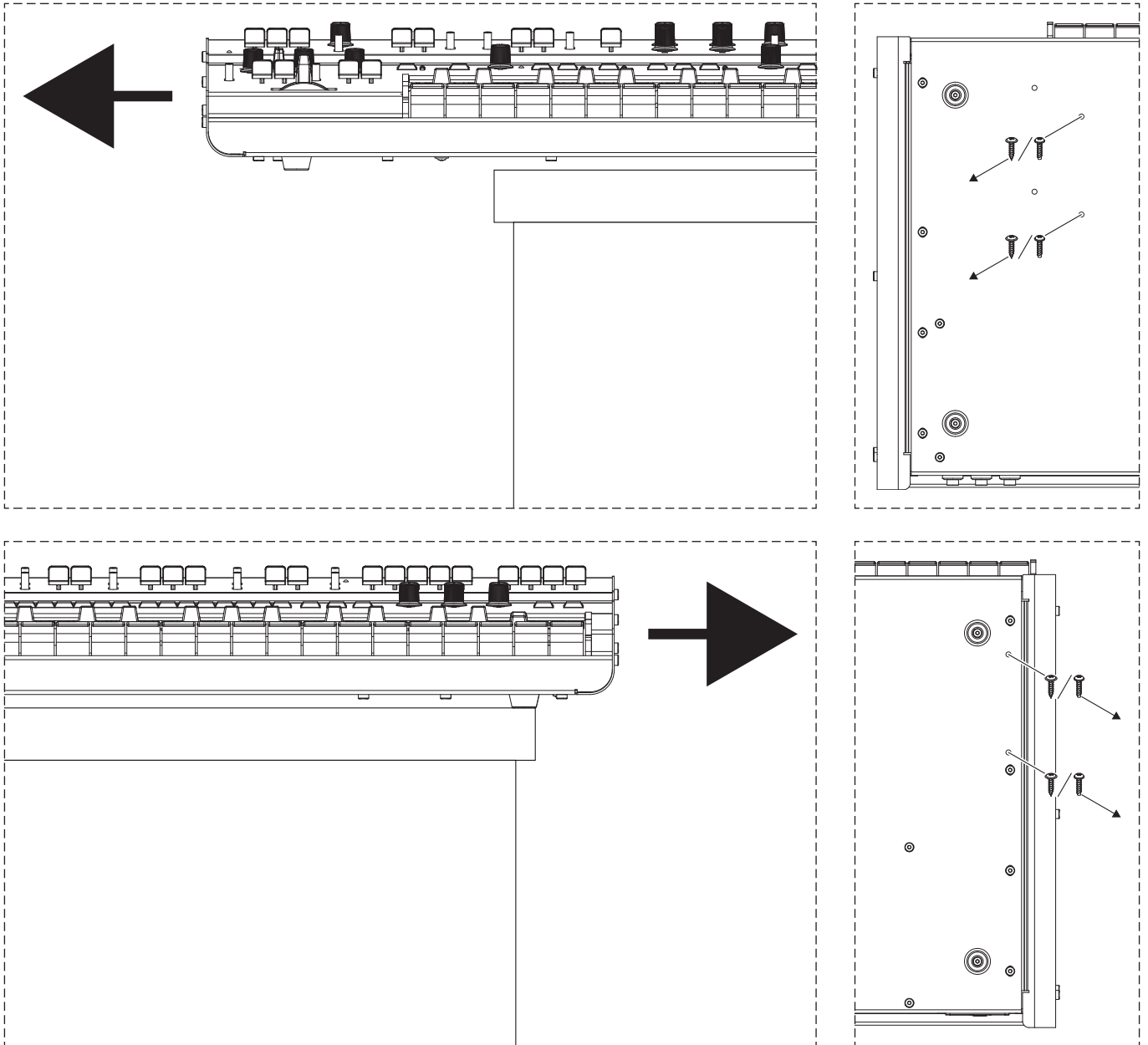

*Earlier Super 6 models were fitted with Phillips head (“crosshead”) screws. To remove these screws, use a Phillips #1 screwdriver instead of the included Torx T20 key.*

8. Slide the Super 6 back onto the surface of your workbench. Remove the two lid retaining front screws and washers from both side panels, one on each side.

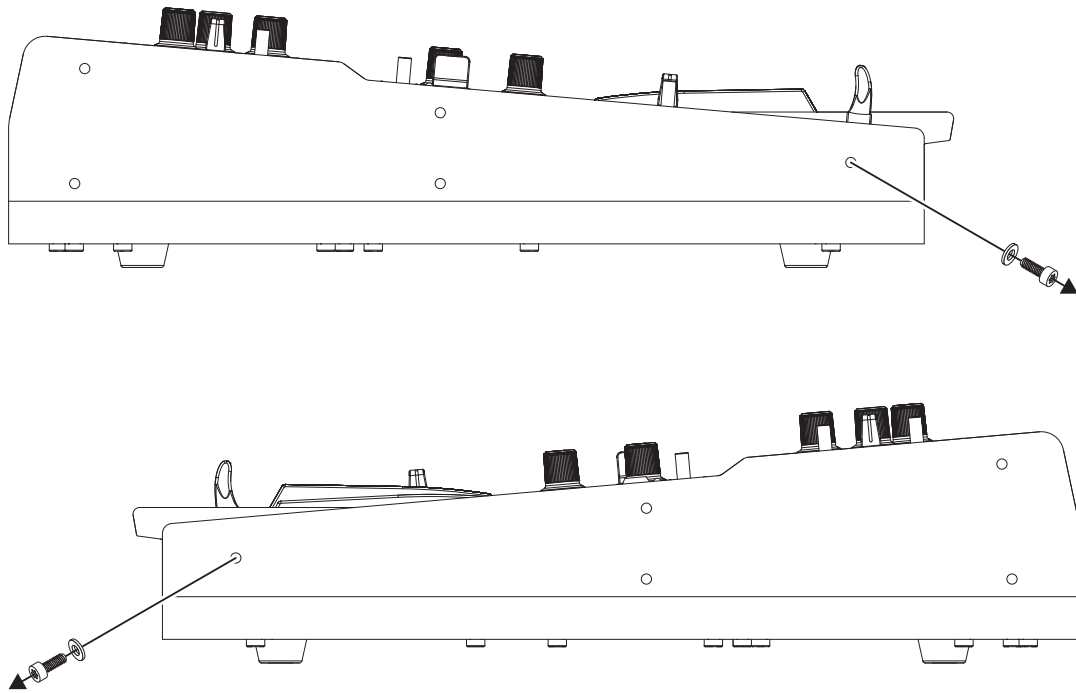

9. Open the lid slightly with one hand and remove the old keyboard from the front of the Super 6 with the other hand.

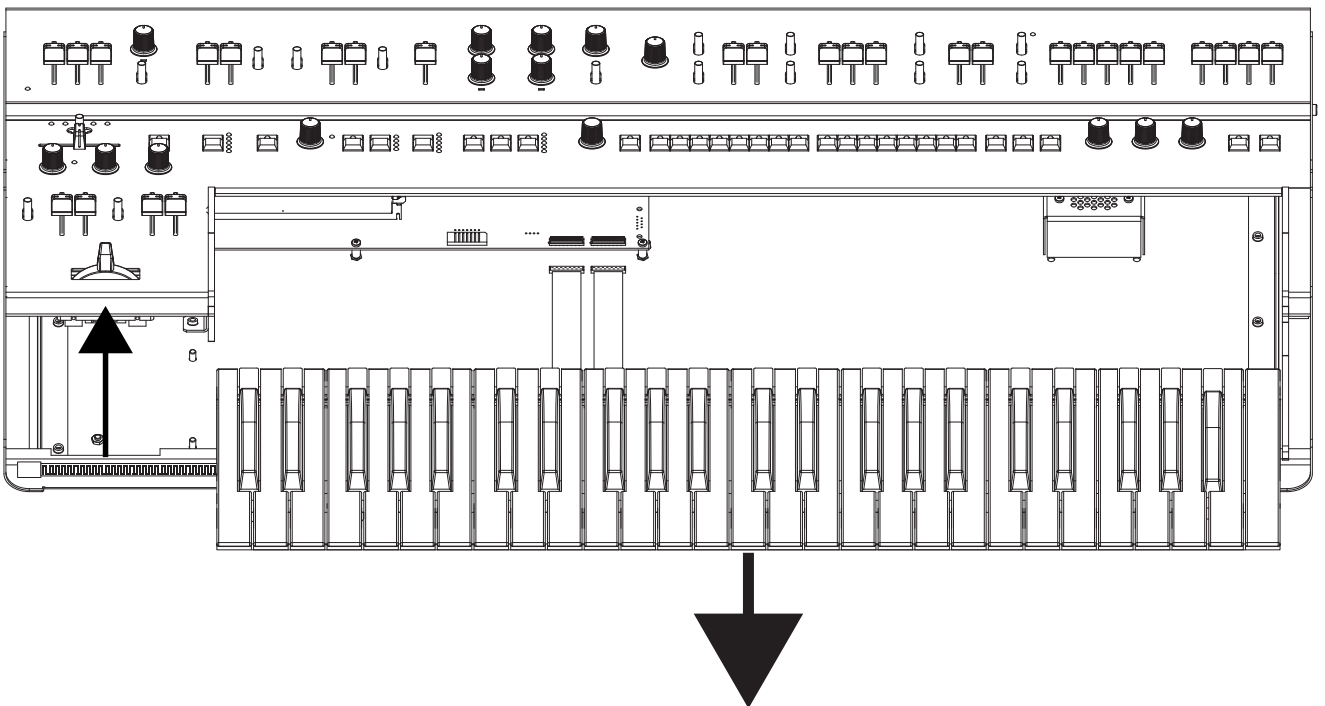

10. Place the SuperTouch 49 keyboard on a soft surface with the keys facing downwards. Fold the cable outwards in the direction shown below.

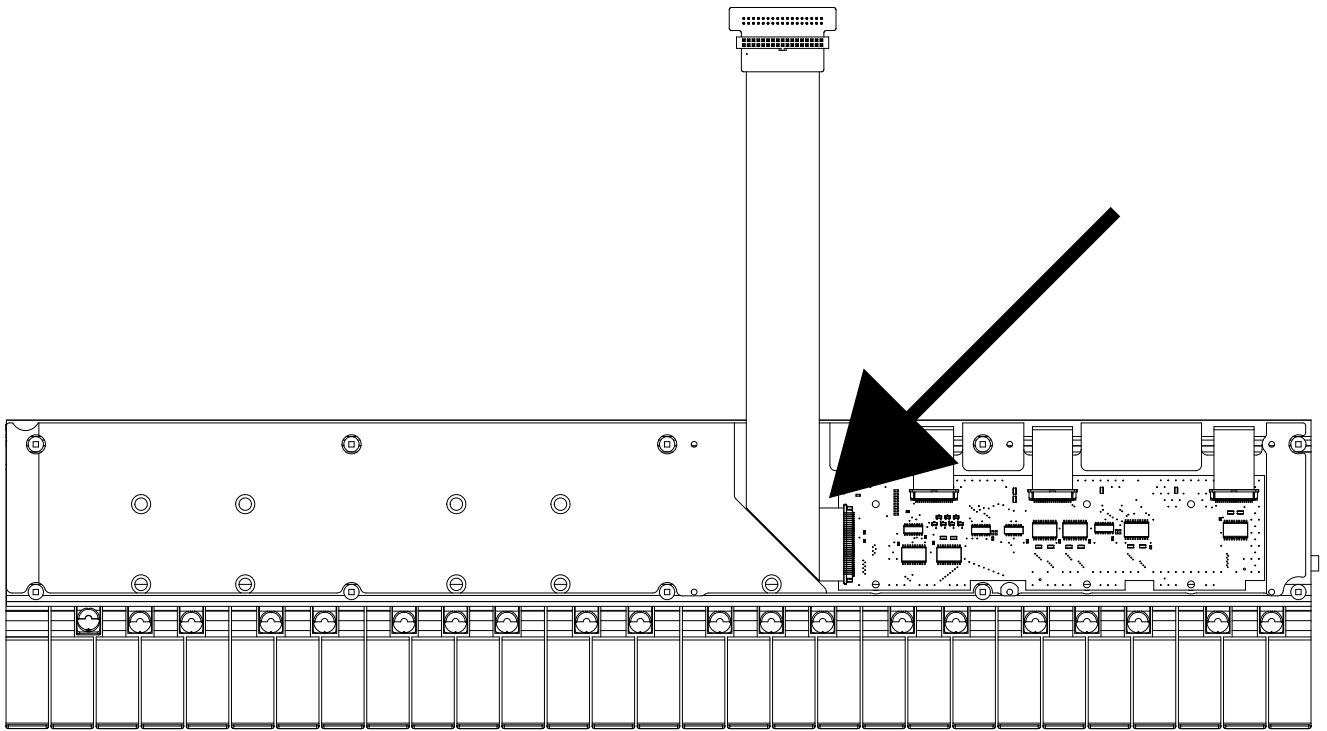

11. Open the lid with one hand and carefully slide the SuperTouch 49 keyboard into the Super 6 from the front, with the attached cable pointing towards the main board.

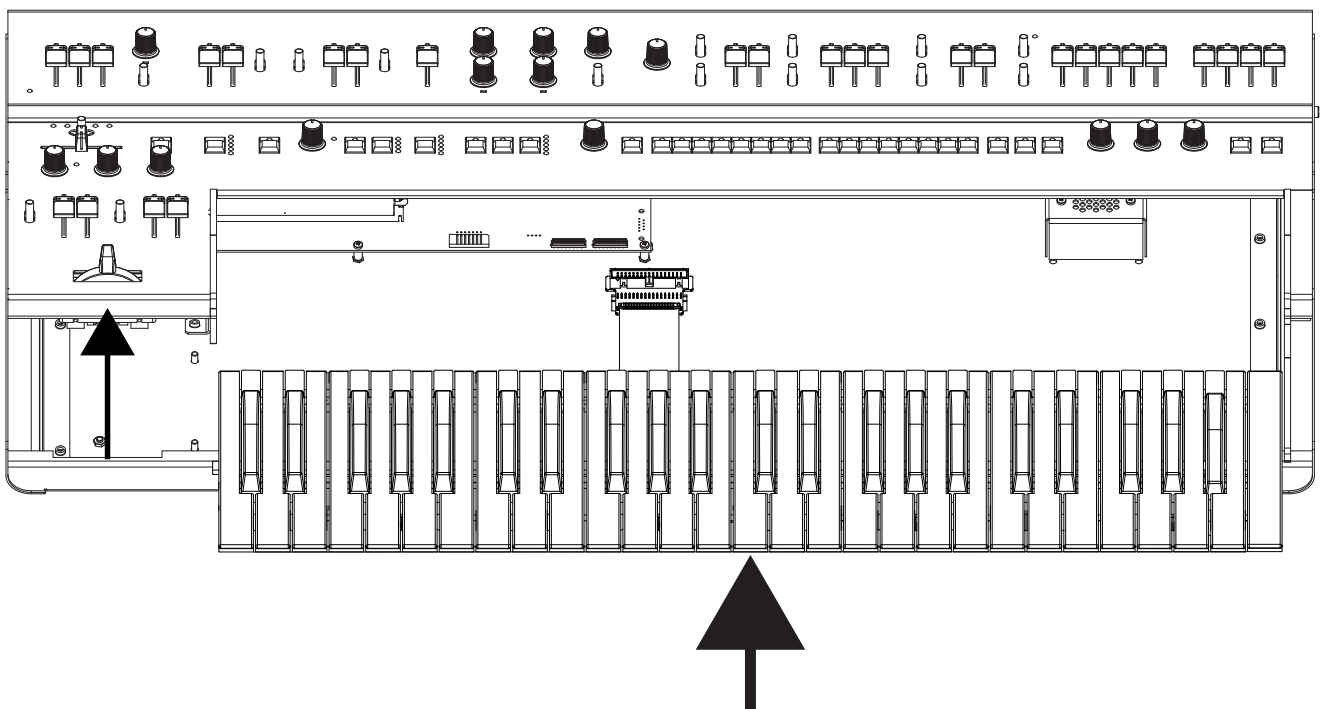

12. With the lid open, slide back the locking clips of the rearmost socket and unplug the IDC cable that runs from the front panel to the main board.

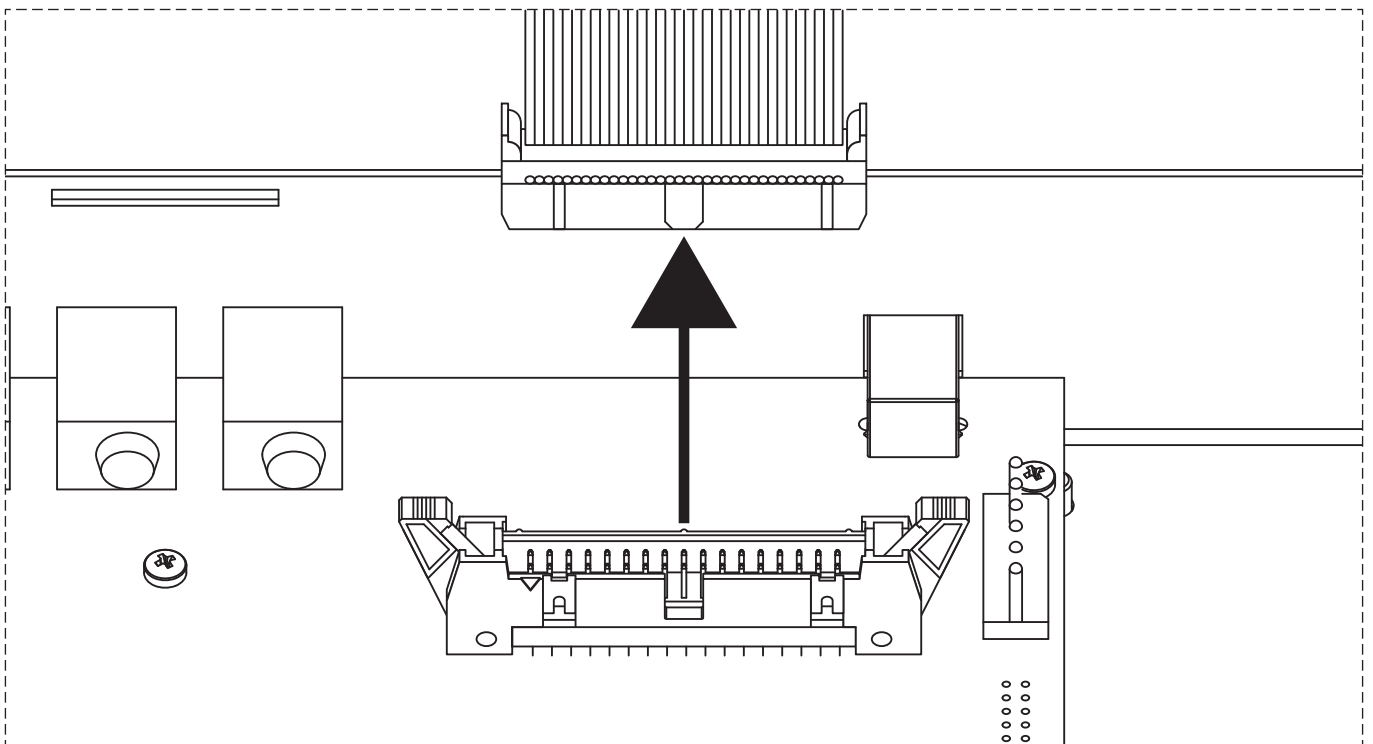
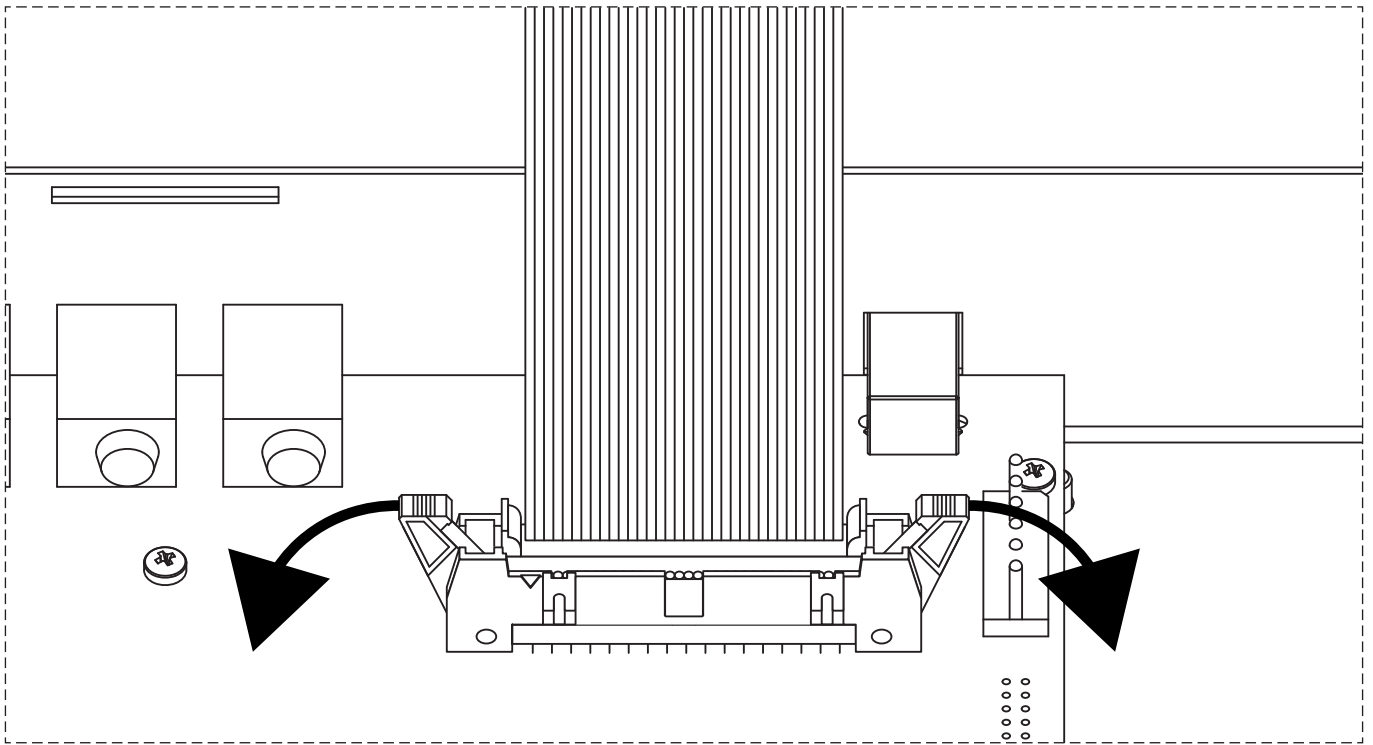

13. Plug the adapter PCB at the end of the keyboard cable into the socket on the main board and close the locking clips.

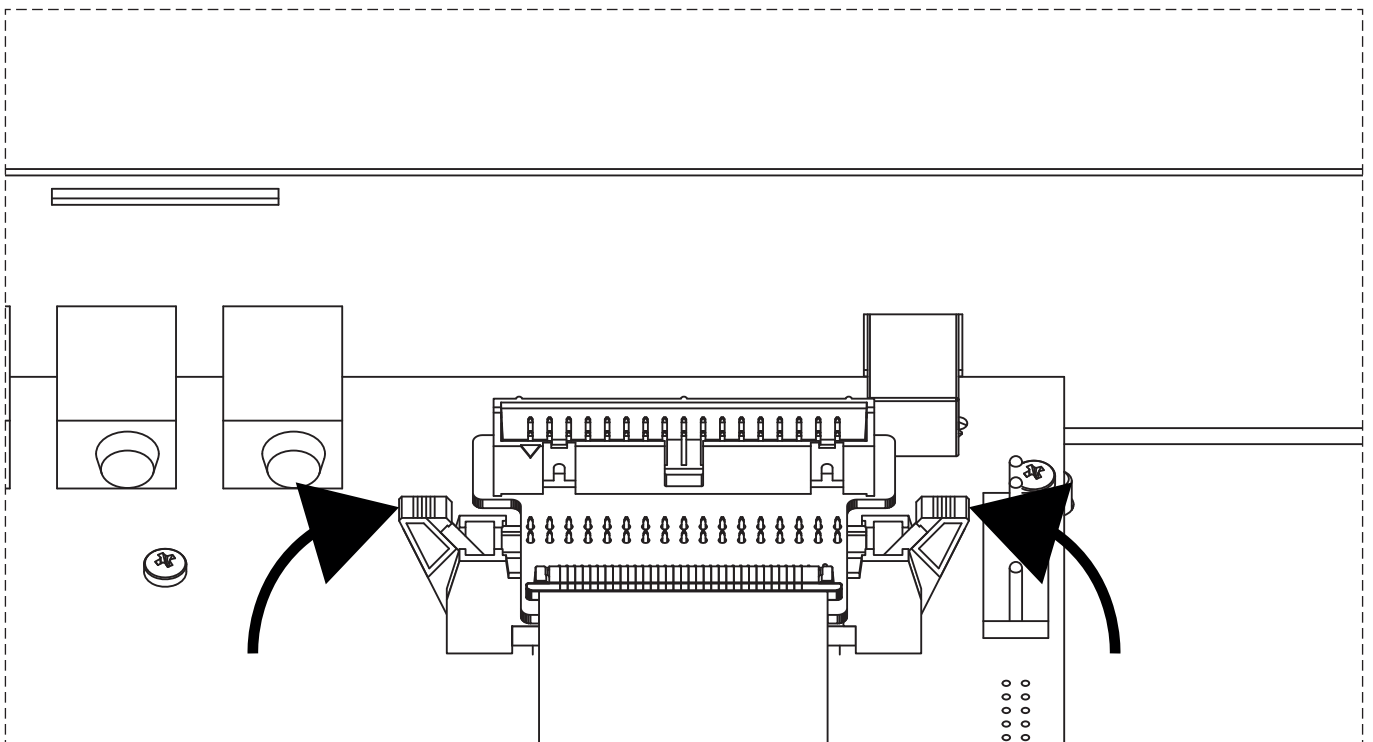
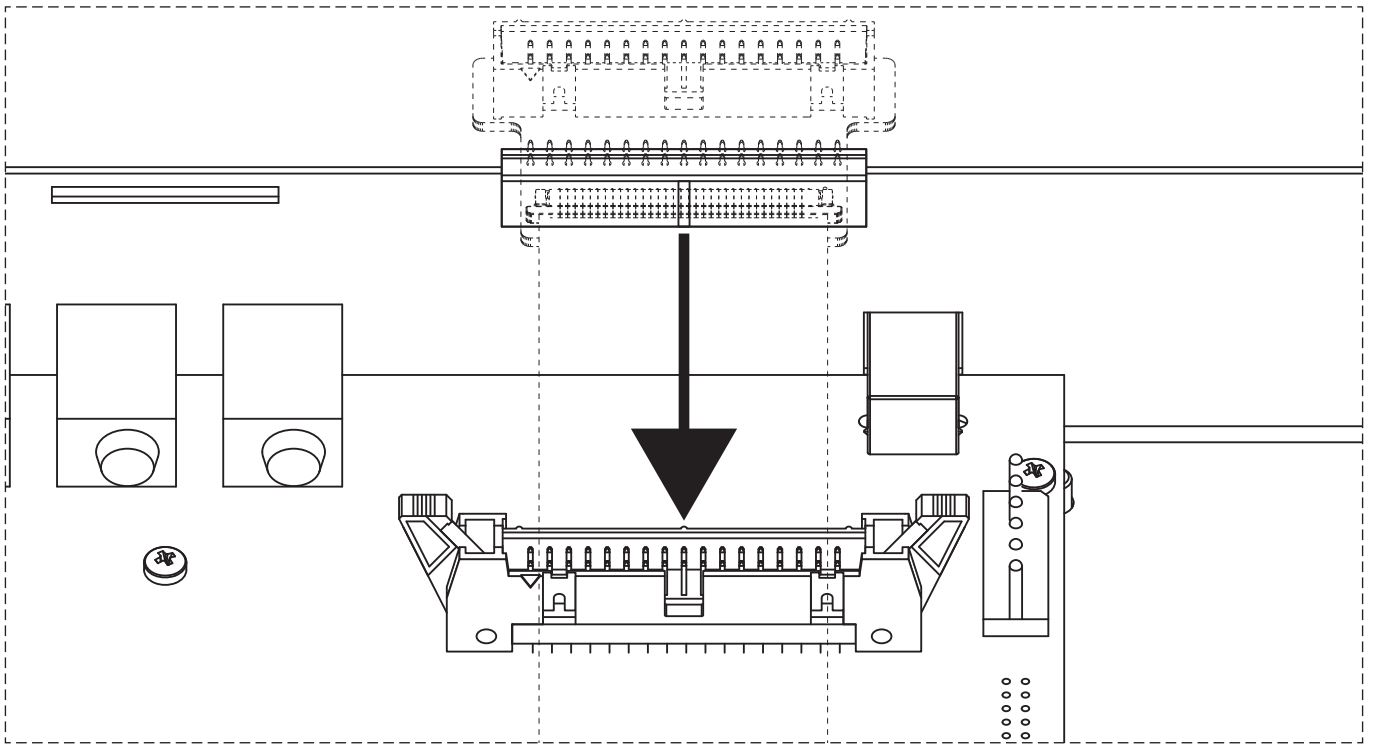

14. Plug the IDC cable from the front panel you unplugged in step 12 into the provided connector on the adapter PCB you installed in the previous step.

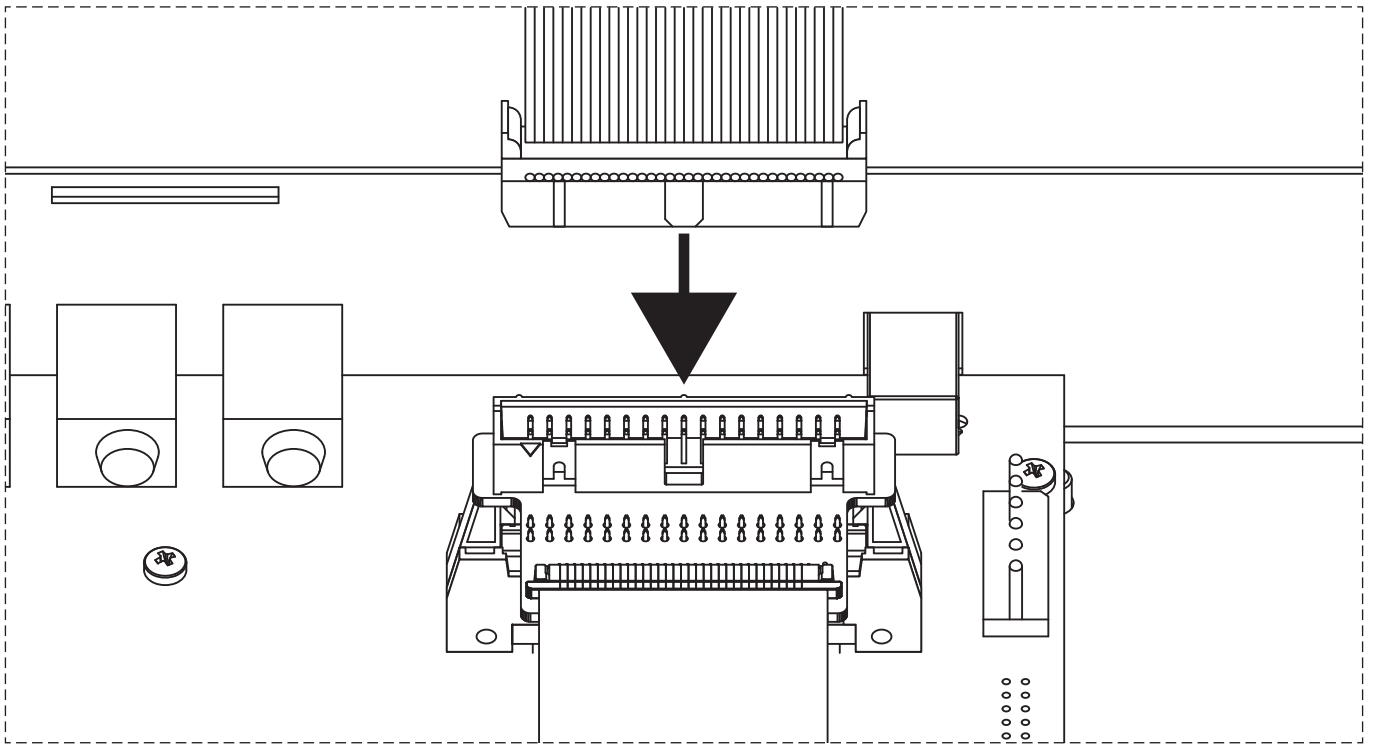

15. Close the lid and attach four of the included 10mm Torx T20 screws to retain the keyboard. These are the four corner screws for the keyboard, which must be inserted first.

Hold the Super 6 flat and slide the instrument so that it protrudes slightly above your workbench so that you can insert the screws from below. Check and adjust the alignment of the keyboard as required.

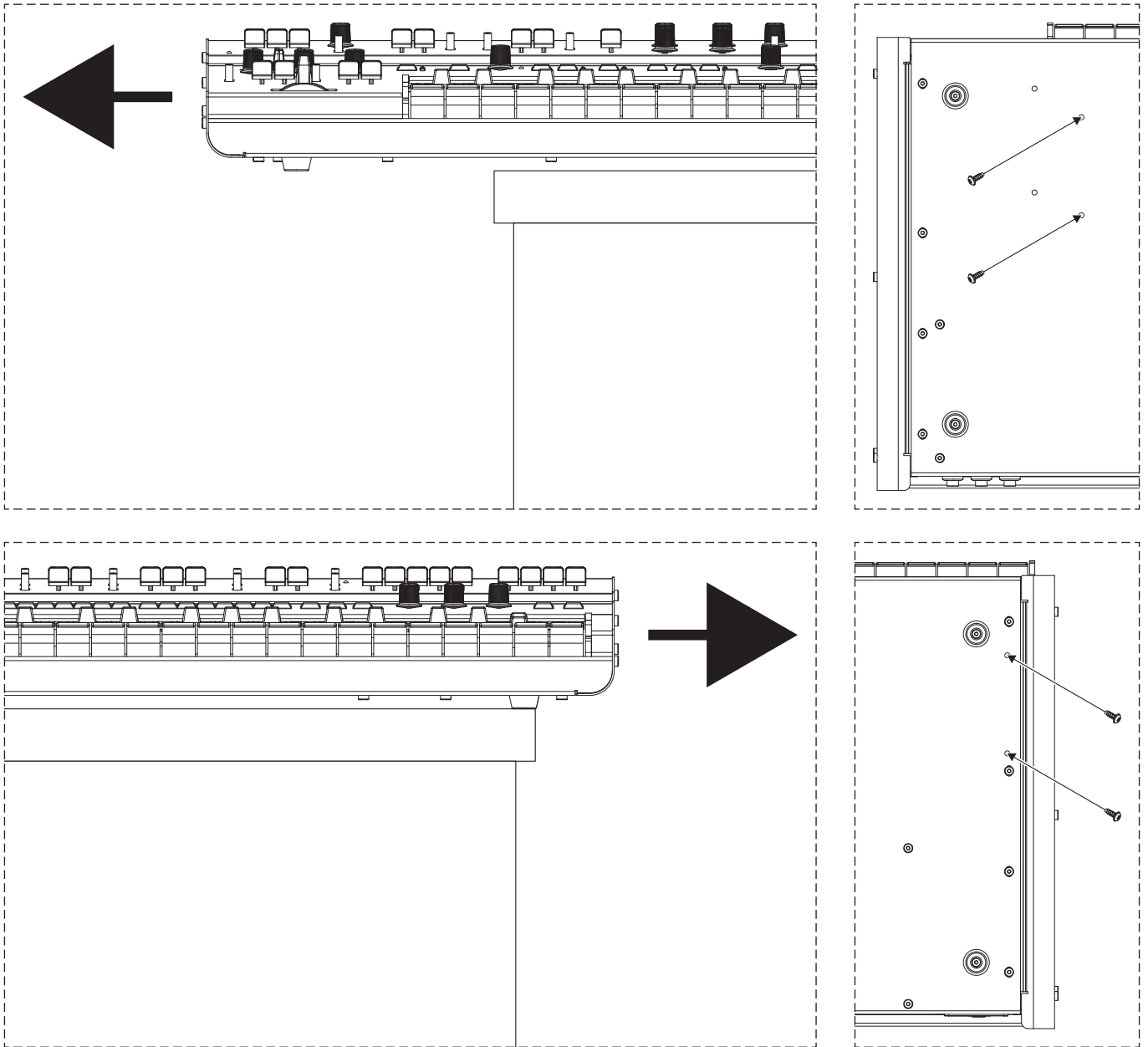

*Do not use the original screws, but the shorter screws provided with the retrofit kit.*

16. Attach the two lid retaining front screws and washers to both side panels, one on each side. This is to prevent the lid from falling open and being damaged when the Super 6 is lifted onto its rear panel in the next step.

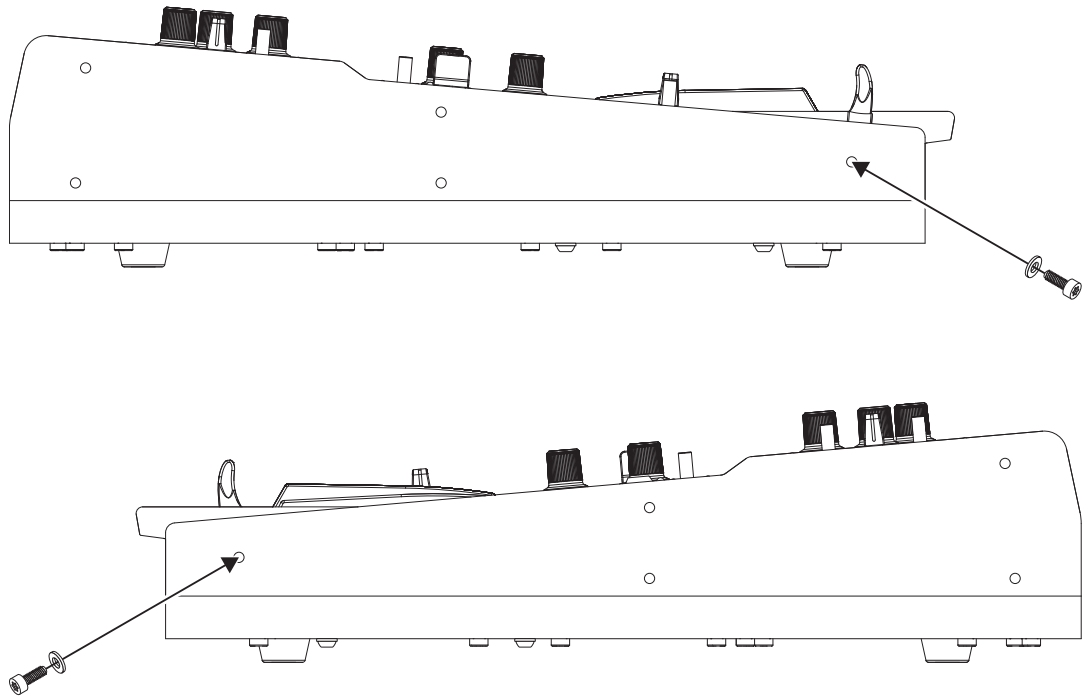

17. Carefully lift the Super 6 onto its rear panel on a soft surface. Attach six of the included 10mm Torx T20 screws to secure the keyboard.

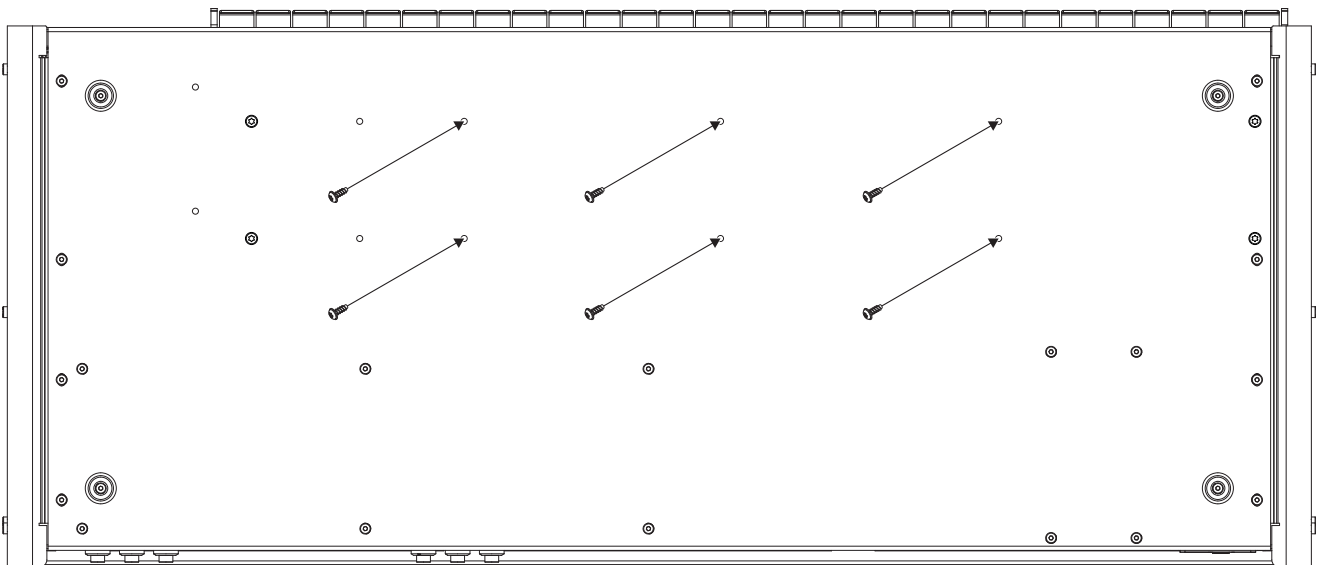

*Do not use the original screws, but the shorter screws provided with the retrofit kit.*

18. Attach the remaining eight screws and washers to both side panels, four on each side.

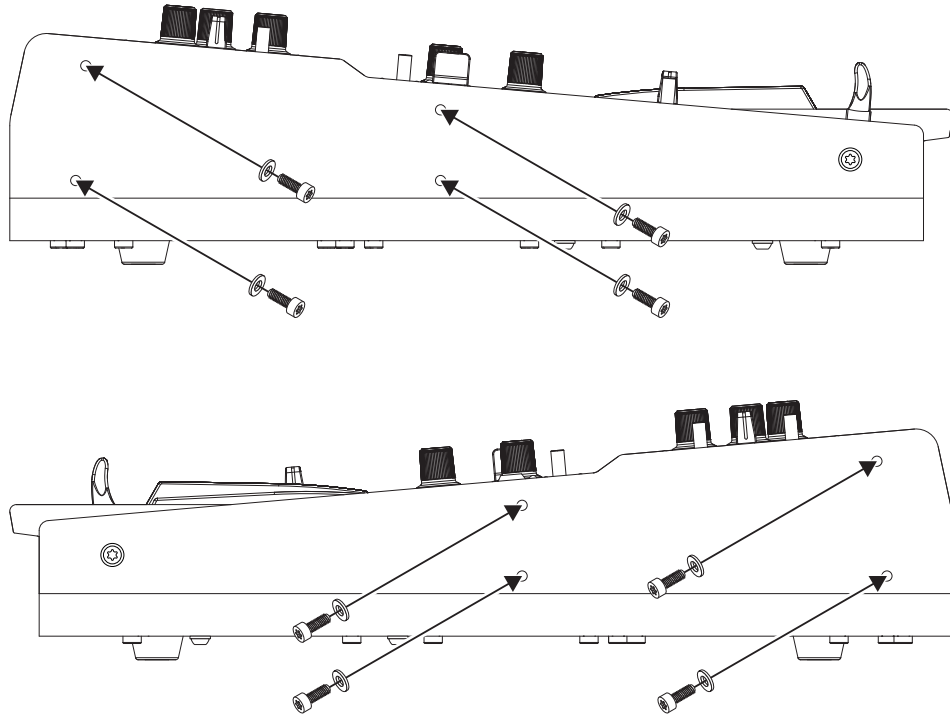

19. Carefully lift the Super 6 onto its rear panel on a soft surface. Attach the two lid retaining screws and washers you removed in step 2 to the underside of the chassis.

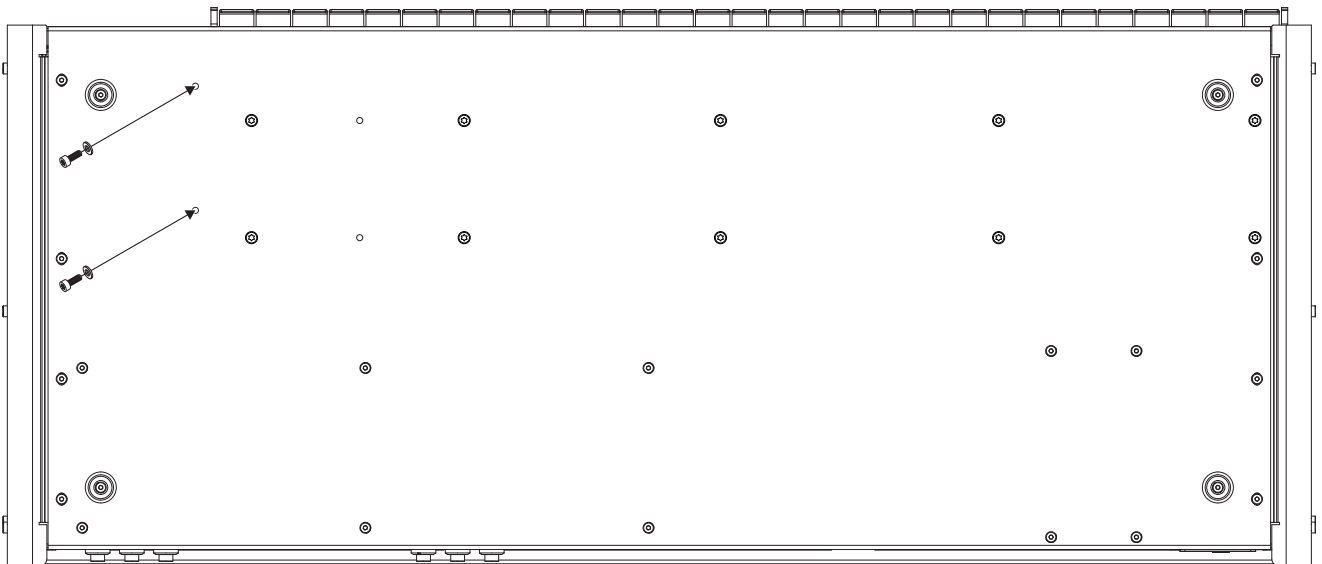

20. Update the firmware to the latest version to ensure that your Super 6 supports the SuperTouch 49 keyboard. Visit [www.udo-audio.com/downloads](http://www.udo-audio.com/downloads) to download the latest Super 6 firmware.

21. Apply the SuperTouch 49 decal sticker.

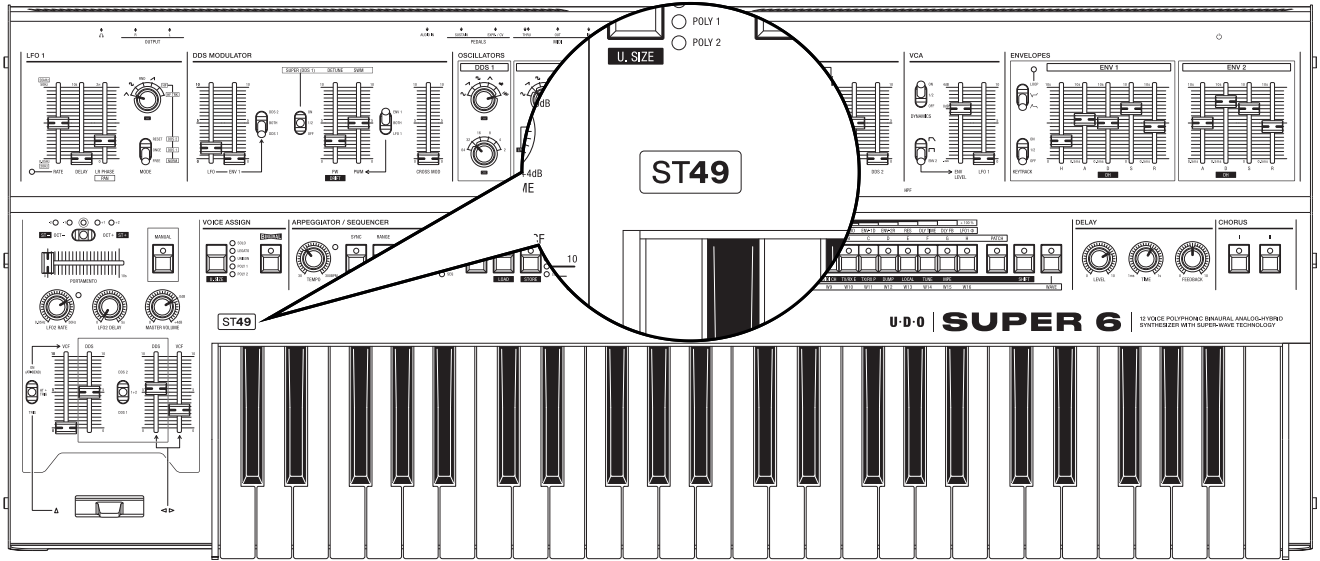

# USING POLYPHONIC AFTERTOUCH

Once you have successfully installed the SuperTouch 49 keyboard, you can change the sound of each held note individually by applying pressure to the corresponding keys.

You don't need to worry about anything else when programming or editing sounds, as you only need to use the existing aftertouch controls on the front panel of the Super 6 to take full advantage of the new polyphonic aftertouch capabilities. In other words, use the aftertouch-related controls in the performance control section or the modulation matrix to determine what should be modulated by polyphonic aftertouch.

## Assigning Polyphonic Aftertouch via the Performance Control Section

In the performance control section, you can use the LFO 2 trigger switch to map modulations to polyphonic aftertouch.

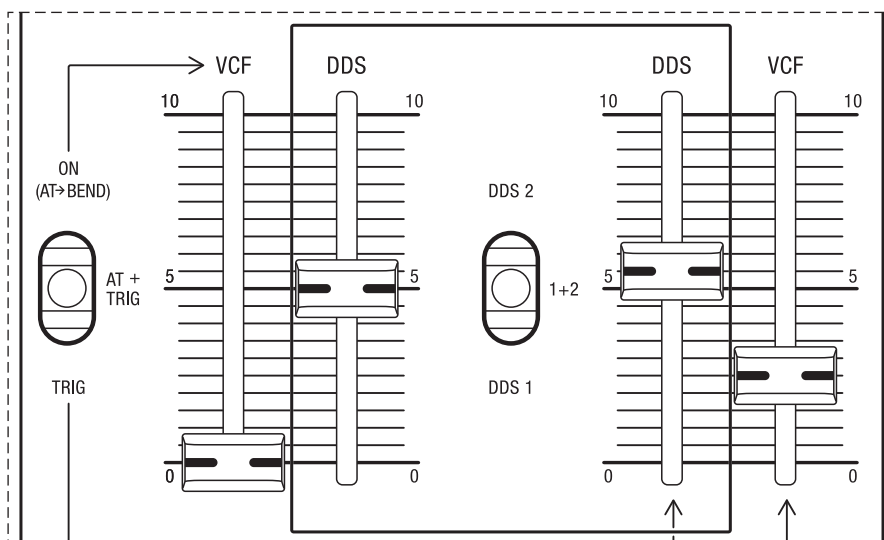

The controls relevant for polyphonic aftertouch in the performance control section, including the LFO 2 trigger switch on the left.

Use the following LFO 2 trigger switch settings to apply polyphonic aftertouch:

- **AT+TRIG:** With this setting, both polyphonic aftertouch and pushing the bender upwards will trigger LFO 2. (If you use the bender and simultaneously apply pressure to a key, only the gesture with the greater effect on the triggering of LFO 2 controls the modulation depth.) Use this setting to control LFO 2 modulations polyphonically, the depth of which is set by the leftmost **VCF** and **DDS** faders.
- **ON (AT->BEND):** With this setting, LFO 2 is permanently on. Additionally, polyphonic aftertouch is now set to trigger the same modulations controlled by horizontal bender movements. Use this setting to control pitch bends that affect one or both oscillators and/or the filter cutoff frequency polyphonically, with the depth set by the rightmost **DDS** and **VCF** faders.

# Assigning Polyphonic Aftertouch via the Modulation Matrix

In the modulation matrix, you can use the modulation source **A.T.** to specify what should be modulated by polyphonic aftertouch.

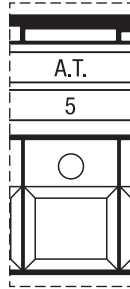

The modulation source aftertouch in the modulation matrix.

To map polyphonic aftertouch to one of the eight fixed destinations in the modulation matrix:

1. Press the **MOD ASSIGN** button to enter the modulation matrix. Its LED starts flashing.
2. Press the **A.T.** button. Its LED now lights up. If polyphonic aftertouch is already modulating a destination in the matrix, the LEDs of the respective buttons (**A-H**) start flashing.
3. Press any destination button (**A-H**) to create a mapping. The LEDs of the source and destination buttons then light up continuously to indicate the mapping lock.
4. Once you have created a modulation mapping, use the **MOD AMOUNT** encoder to dial in the modulation amount. The LEDs of buttons **1-8** and **A-H** indicate the respective setting.
5. Press the **PATCH** button once to exit the modulation matrix and return to patch mode.

To map polyphonic aftertouch to parameters that are not available in the modulation matrix:

1. Press the **MOD ASSIGN** button to enter the modulation matrix. Its LED starts flashing.
2. Press and hold the button labelled **A.T.**
3. While holding the **A.T.** button, move any patch-related parameter on the front panel you wish to modulate. An LED scroll across buttons **1-8** and **A-H** indicates a mapping lock.
4. Once you have created a modulation mapping, use the **MOD AMOUNT** encoder to dial in the modulation amount. The LEDs of buttons **1-8** and **A-H** indicate the respective setting.
5. Press the **PATCH** button once to exit the modulation matrix and return to patch mode.



*If a parameter cannot be assigned as a modulation destination, there will be no LED scroll. In general, only parameters that are represented by continuous controls can be assigned. This excludes toggle and rotary switches.*

# SUPPORT INFORMATION

---

If you are experiencing any issues with your Super 6 and/or SuperTouch 49 keyboard, please contact our technical support at [support@udo-audio.com](mailto:support@udo-audio.com).

Please provide the following information when you contact us:

- Instrument name
- Serial number
- Firmware version
- Purchase date (new or used) and location (country, dealer)

If you haven't already done so, make sure to register your product through our [website](#).

You may also visit our [FAQ section](#) or [user forum](#) to check if your question has already been answered.

# TROUBLESHOOTING

---

Symptom	Suggested cause and corrective action
---------	---------------------------------------

---

**Uneven gaps between left and right side of keyboard**

Keyboard is mis-aligned in chassis. Loosen (but do not fully undo) all 10 Torx T20 screws, and re-align the keyboard.

---

**Black keys make 'clacking' sound when pressed**

Keyboard is aligned too far backwards in chassis. Loosen (but do not fully undo) all 10 Torx T20 screws, and move the keyboard further forward. Re-tighten screws.

---

**Front panel unresponsive**

Front panel cable has not been re-inserted correctly. Re-open chassis and ensure front panel cable is fully re-inserted into the adapter PCB (**see Step 14**).

---

**Keyboard unresponsive**

Software is not up-to-date. Visit [www.udo-audio.com/downloads](http://www.udo-audio.com/downloads) to download the latest Super 6 firmware.

---

Adapter PCB has not been installed correctly. Re-open chassis and ensure that the adapter PCB has been installed in the motherboard (**see Step 13**).

---

Keyboard cable has detached. Re-open chassis and ensure that the keyboard cable is fully inserted into the adapter PCB. If this is unsuccessful, remove the keyboard and check that the folded cable is mated at the keyboard end (**see Step 10**).

---

Keyboard cable has been damaged. Inspect the cable from the keyboard to the motherboard, and contact UDO if visibly damaged.

